

SIERRA 5

OWNERS MANUAL



DEAD AIR
silencers



SIERRA 5

WELCOME TO DEAD AIR SILENCERS

Thank you for purchasing our products and supporting the Second Amendment.

Dead Air Silencers was co-founded by one of the industry's true icons, Mike Pappas, and is supported through distribution and manufacturing by our industry partners. The goal of our company is simply to make the best firearm sound suppressors on the market. Every suppressor is manufactured in the U.S.A. by American craftsmen utilizing the finest materials. As Mike says, "We wouldn't have it any other way. We want the best products, made by Americans for Americans." That said, it's our customers that make our products possible and we appreciate each and every one of you that have supported us.

We place an absolute premium on customer service. We demand that our customers receive prompt and rewarding care and support. Feel free to contact us at 801-857-4232 or info@DeadAirSilencers.com with any questions or concerns you may have. Once again, thank you for your support.



TABLE OF CONTENTS

PRODUCT OVERVIEW	4
GET TO KNOW YOUR SIERRA-5	5
ADAPTER INSTALLATION	6
ADAPTER REMOVAL	7
FRONT CAP INSTALLATION	8
SUPPRESSOR INSTALLATION & REMOVAL	9
PIN & WELDING YOUR SIERRA-5	12
WARRANTY	14
LAWFUL USE AND POSSESSION	15
CONTACT INFORMATION	15



FIREARMS ARE DANGEROUS! REVIEW THIS OPERATOR'S MANUAL IN FULL BEFORE USING YOUR SUPPRESSOR. FAILURE TO FOLLOW THE INSTRUCTIONS LISTED BELOW COULD RESULT IN DAMAGE TO YOUR FIREARM AND/OR SERIOUS PERSONAL INJURY OR DEATH. DO NOT ATTEMPT TO USE YOUR FIREARM AND/OR SUPPRESSOR UNTIL YOU HAVE THE PROPER TRAINING TO DO SO.

1. PRODUCT OVERVIEW

Compact. Lightweight. Modular. The SIERRA-5 5.56mm suppressor was designed for users that want the versatility of quickly and easily configuring their suppressor with a variety of mounting and end cap options to tailor the assembly to their specific needs.

The SIERRA-5 is constructed of 17-4 Stainless Steel and Cobalt 6. With an overall length of 5.35 inches you'll hardly know you're running suppressed until you pull the trigger. The SIERRA-5 features a high-efficiency baffle design that delivers world-class sound reduction at the muzzle, reduced back-pressure, and outstanding muzzle-flash mitigation.

Don't let the light weight fool you. It will enjoy long walks in the woods with you, but the SIERRA-5 will also handle that three-day carbine class and ask for more.

Caliber	Sound Data	Barrel Length	Ammunition
5.56x45	138.0	16"	M855

Test Equipment

G.R.A.S 1/4" Pressure microphone Type 40BD // G.R.A.S 1/4" CCP Preamplifier Type 26CB // National Instruments NI USB-4432 - DAQ 102.4 kS/s, 24 Bits, +/-40 V, IEPE // National Instruments - LabVIEW software

A note on our sound testing...

At Dead Air Silencers, we pride ourselves with both the innovative and scientific process we use to design our products. Part of improving a product is measuring, and you can't improve what you can't accurately measure.

While we test across the sound spectrum for frequency and "perceived" sound, we also test for peak sound pressure in decibels [dB] at various locations. We're keenly interested in balancing at-ear and muzzle results for the best possible shooting experience.

Our published sound testing is performed in accordance with MIL-STD-1474D, which doesn't exactly provide the best indicator of how something sounds, but it does provide a very conservative and consistent muzzle sound level that can be reliably compared to previous results or known baselines. Our particular system provides very conservative results that you can rely on as accurate and representative of what can be experienced with our products.

Other manufacturers may move the microphone to other locations to provide more favorable readings, such as back behind the muzzle of the suppressor or only at the ear of the shooter. Some even rely on dealer/media sources to measure using systems that typically provide very favorable results. To keep all of this data in context as an end user, you should know this typically results in a bias of several decibels.

Our stated results are from our Engineering group, not our Marketing group.

GENERAL CONSIDERATIONS:

Ammunition: Ammunition will have a huge influence on how your new suppressor functions. Use good quality factory-new ammunition in your firearm.

Concentricity: In order to reduce the risk of a baffle strike, it is important to ensure that your barrel threads are aligned concentrically with the bore axis of your host weapon's barrel. If you do not have the means to verify this, it is strongly recommended that you have a competent gunsmith verify if for you.



CHECK YOUR WEAPON'S CHAMBER AND MAKE CERTAIN THAT THE WEAPON IS UNLOADED AND THE MAGAZINE REMOVED BEFORE PROCEEDING ANY FURTHER. IF THERE IS ANY QUESTION OR DOUBT, CONSULT THE OPERATOR'S MANUAL APPLICABLE TO YOUR FIREARM AS TO THE PROPER PROCEDURE FOR CLEARING AND/OR UNLOADING YOUR WEAPON. DO NOT INSTALL YOUR NEW SUPPRESSOR ON A FIREARM WITH A CLOSED ACTION!

2. GET TO KNOW YOUR SIERRA-5

SIERRA-5 KM



SIERRA-5 XM



SIERRA-5 MODULARITY



3. ADAPTER INSTALLATION

When discussing directionality during assembly, “back” will always be toward the host weapon, “front” will always be away. For example, the Direct Thread Mount that connects to the barrel goes into the “back” of the suppressor, and the Front Cap threads onto the “front”.

STEP ONE:

Choose your preferred mount adapter option and coat the threads with a high-quality grease. Your Sierra-5 ships with either a KeyMo Adapter or Xeno Adapter.

Note: If you experience loosening of the mount due to the suppressor experiencing heavy heat cycles, then it's recommended to degrease the threads and use a high temperature thread locker. Note that it requires high heat to remove many high-strength thread lockers. Dead Air recommends using a medium strength, high temperature thread locker like Vibra-Tite 123 for average operating conditions.

STEP TWO:

Thread the adapter into the suppressor until it bottoms out on the rear suppressor face.

STEP THREE:

Use the Hook Spanner Wrenches to catch the notches in the parts so that the mount is being turned Clockwise and the suppressor Counter-Clockwise. It's recommended to align the hooks so that there's an inch or two between the ends to maximize the leverage as you squeeze them together.

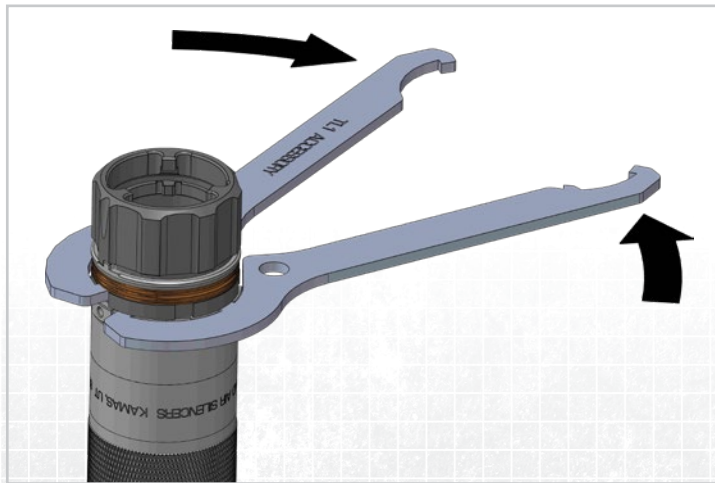

4. ADAPTER REMOVAL

STEP ONE:

Use the Hook Spanners to catch the notches in the parts so that the mount is being turned Counter-Clockwise and the suppressor Clockwise. It's recommended to align the hooks so that there's an inch or two between them to maximize the leverage over them as you squeeze them together.



YOU MAY NEED TO HEAT THE SUPPRESSOR UP TO LOOSEN THE THREADS. PAY SPECIAL ATTENTION TO THE HEATED SURFACES TO AVOID BURNS!



WHEN THE TORQUE BREAKS BETWEEN THE TWO PARTS, THE WRENCHES MAY SWING ENOUGH TO CREATE A PINCH POINT. ALWAYS BE CAREFUL AND MIND THE GAP!

STEP TWO:

Continue loosening mount and remove from back of suppressor. Clean threads and follow instructions for Mount Installation for the new mount.

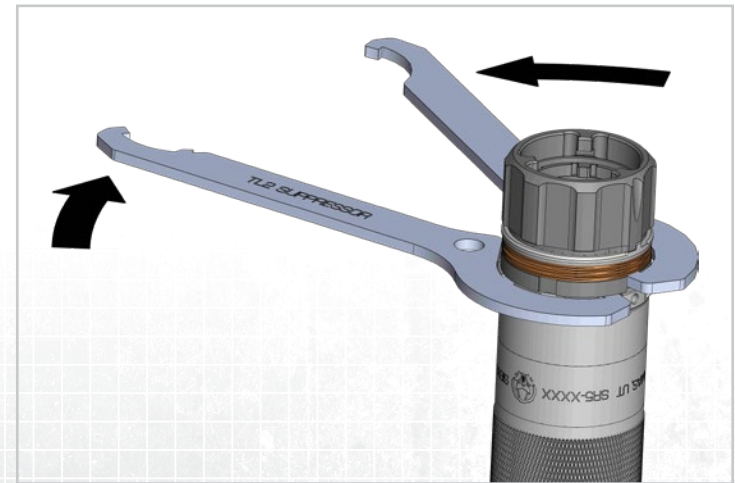

5. FRONT CAP INSTALLATION

STEP ONE:

Align the pins in the Sandman Front Cap Tool (DA208—sold separately) into the holes cut into the front cap. Ensure tool is flat against the front cap with the pins evenly and fully engaged and apply torque Counter-Clockwise to loosen and remove.

STEP TWO:

Clean threads and taper. Apply high quality grease to the surfaces and install new cap and hand tighten.

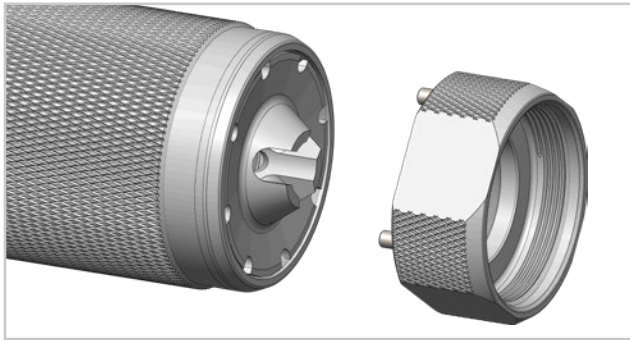

Pro Tip: You can store your cap that's not in service on the tool itself!

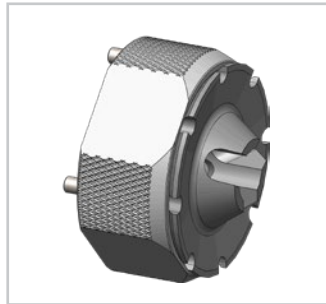

6. INSPECTION UPON ASSEMBLY

All components should be snug with no gaps or rattling. If any component is not fully tightened, check threads for any damage or debris. Clean both mating parts as necessary and repeat the tightening step.

NOTE: DEBRIS ON THE THREADS AND TAPER SURFACES MAY CAUSE MISALIGNMENT OF SUPPRESSOR PARTS AND ALLOW FOR PROJECTILE STRIKES ON BAFFLES OR THE FRONT CAP.

7. INSTALLATION AND REMOVAL

STEP ONE: PREPARATION

Your suppressor is intended to be attached to the muzzle end of your firearm. It will thread directly onto your existing barrel, which will vary based on host weapon. Because this is a modular system, there are a few options available for mounting it to your host weapon.

For direct thread use, choose a thread mount appropriate to your firearm. For a fast attach system, a KeyMo or Xeno adapter will provide a bombproof attachment system paired with our various flash hidere and brakes.

We recommend checking tightness often. All direct thread suppressors will loosen with use and are very dependent on the quality of the barrel threading. A loose suppressor mount will shift the point of impact due to misalignment of the suppressor and may cause the projectile to strike the baffles or front cap, damaging the suppressor. Do not over-tighten the suppressor with any assorted tools or wrenches, as such actions may result in damage to your firearm, the suppressor, or both. Hand tightening the suppressor onto the barrel is preferred. If extra tightness is desired, the included Hook Spanner wrenches can provide a bit of additional torque during installation.

Before installation, ensure the threads of the host firearm's barrel are clean and lubed before carefully threading the suppressor onto the muzzle end of your firearm. Take care not to cross thread or force the suppressor onto the muzzle threads. In the event that the suppressor does not smoothly thread onto your firearm, stop the installation process and immediately contact our Customer Service Department for further instruction. Ensure the suppressor is tightened all the way against the shoulder of the barrel. Longer threads will require the suppressor to seat on the muzzle face and the back of the Direct Thread Adapter may not contact the shoulder. DO NOT thread onto barrels that don't have a proper shoulder or muzzle face that is aligned and square with the bore.



IF THE MOUNT DOES NOT SMOOTHLY THREAD ONTO YOUR FIREARM STOP THE INSTALLATION PROCESS AND CONTACT OUR CUSTOMER SERVICE DEPARTMENT. FAILURE TO PROPERLY INSTALL YOUR SUPPRESSOR COULD RESULT IN SERIOUS INJURY, DAMAGE TO THE SUPPRESSOR, THE HOST WEAPON, THE USER, AND/OR A THIRD PARTY.



OUR PRODUCTS ARE CALIBER SPECIFIC. UNLESS STATED OTHERWISE ON THE SUPPRESSOR ITSELF OR ON THE PACKAGING, THE SIERRA-5 SUPPRESSOR WILL NOT FUNCTION SAFELY WITH ANY CARTRIDGE WITH PRESSURES HIGHER THAN 22 CREEDMOOR. USE OF YOUR SUPPRESSOR OUTSIDE OF ITS INTENDED SCOPE COULD RESULT IN DAMAGE TO YOUR FIREARM, DAMAGE TO PROPERTY, BODILY INJURY, OR DEATH.

STEP TWO: MOUNTING THE SUPPRESSOR TO BARREL

The suppressor can only go on one way and come off one way. Before use, make sure that the suppressor is firmly and rigidly mounted to the firearm. Failure to do so could result in damages to your firearm and damage to the suppressor. Visually inspect the suppressor after it is mounted in order to confirm that it is mounted straight to the centerline of the bore and is otherwise not canted. If the suppressor is not in line with the bore immediately stop the installation process and contact our Customer Service Department. Use of the suppressor while improperly mounted could cause irreparable harm to your suppressor and will cause poor performance and reduced accuracy.

Be aware of the barrel thread on your barrel and ensure the matching Direct Thread Adapter is properly installed in the suppressor. Note that some threads are left-handed, meaning they turn the opposite direction than what you may be used to.

If the suppressor loosens during firing, one of the Hook Spanner wrenches may be used to snug it onto the barrel.

Barrel Torque for both Key-Mount and Xeno muzzle devices and Direct Thread Adapters shall not exceed 30 ft-lbs. A target of 25 +/- 5 ft-lbs. is optimal.

STEP THREE: REMOVING THE SUPPRESSOR



THE SUPPRESSOR MAY BECOME EXTREMELY HOT AFTER USE.

NEVER GRAB A HOT SUPPRESSOR AS IT CAN RESULT IN BURNS AND INJURY.

PRO TIP! The Hook Spanner wrench may be used to loosen a suppressor that's too hot to touch.

To remove the suppressor when the Direct Thread Adapter is installed, simply rotate the body of the suppressor counter-clockwise until it begins to unthread from the muzzle of the host weapon. If the thread is left-handed, then unscrew by rotating clockwise.

To remove the suppressor with the Key-Mo adapter installed, simply rotate the body counter-clockwise approximately $\frac{3}{4}$ of full turn at which point it will stop turning. The suppressor may now be slipped off the brake or flash hider. In this state, it's ready for re-installation upon its next use.

If the suppressor unthreads from the mount with the mount remaining on the barrel, then the Hook Spanner can be used to loosen it. If greater torque is needed, or if it's under a handguard, then a $\frac{3}{4}$ " socket can be used to remove it by engaging the hex tool feature. Just pretend you're doing that spark plug maintenance on your vehicle that you've been putting off for some time now.

8. PINNING AND WELDING SIERRA-5 TO HOST FIREARM

The SIERRA-5 was designed to facilitate the process of pinning and welding the suppressor onto a 1/2-28 threaded host firearm barrel.

STEP ONE:

Install an LT301 1/2-28 Direct Thread Mount onto the muzzle threads of a host firearm and torque it to 25 ft-lbs.

STEP TWO:

Using the existing hole in the wrench flat of the LT301 mount as a guide, and a 3/32" drill, drill a hole in the barrel that measures 5/32" from the surface of the wrench flat.

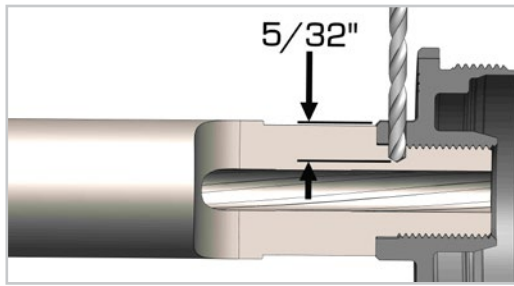

STEP THREE:

Install a 3/32" diameter x 3/16" long stainless-steel pin in the hole. The head of the pin should sit just below the surface of the wrench flat on the LT301 mount.

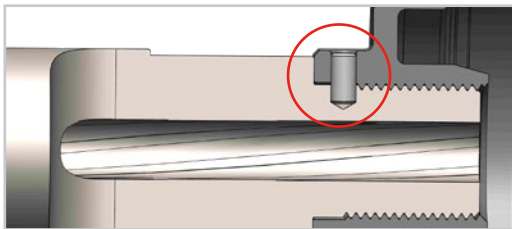

STEP FOUR:

Weld the pin to the LT301 mount, permanently attaching the mount to the host firearm barrel.

STEP FIVE:

Install SIERRA-5 suppressor onto the LT301 mount and torque it to 25 ft-lbs.

STEP SIX:

Using the existing hole in the blast chamber of the SIERRA-5 as a guide, and a 3/32" drill, drill a hole in the mount that measures 5/32" from the surface of the blast chamber.

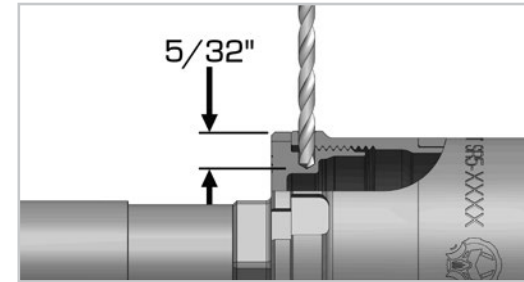

STEP SEVEN:

Install a 3/32" diameter x 3/16" long stainless-steel pin in the hole. The head of the pin should sit just below the surface of the SIERRA-5 blast chamber.

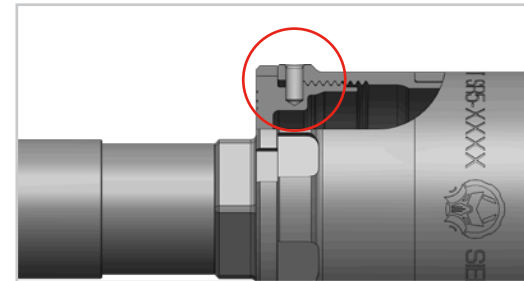

STEP EIGHT:

Weld the pin to the SIERRA-5 blast chamber, permanently attaching the suppressor to the LT301 mount.

5. DISCLAIMER

The manufacturer is not responsible for damages or injuries due to the misuse or unintended use of its products. This product is potentially dangerous and, as such, adequate safety precautions must be taken in order to avoid damage to your firearm, damage to third parties, bodily injury or death. Please consult our website for further details at:

WWW.DEADAIRSILENCERS.COM OR CALL 801-857-4232

6. WARRANTY

We provide a lifetime warranty against all manufacturing defects and damages caused by the normal use of this product. The manufacturer will repair or replace free of charge any suppressor manufactured by, or at the direction of, Dead Air Silencers. The product is sold "as is" with no further implied contractual rights or warranties beyond those expressly stated herein.

The warranty does not apply to certain conditions or acts. It is at the sole discretion and determination of Dead Air Silencers if a particular defect or condition is covered by this warranty. Conditions not covered include, but are not limited to: modifications, abuse, neglect, use of defective ammunition, use of improperly sized ammunition, and criminal conduct. Sound Moderation Technologies assumes no liability for damages or bodily injury caused by such acts or omissions as previously described. Abuse and neglect are defined as usage outside of the reasonable scope for which the product is intended, thus contributing to the accelerated and unreasonable premature wear of the suppressor itself.

If a repair is indicated then the owner must contact our Customer Service Department at 801-857-4232. A Dead Air Silencers representative will make arrangements for return of the suppressor at manufacturer's shipping expense. **DO NOT SHIP THE SUPPRESSOR FOR REPAIR WITHOUT FIRST CONTACTING CUSTOMER SERVICE AND DO NOT SHIP IN ANY EVENT WITHOUT A COPY OF THE APPROVED BATF FORM.** When you ship the suppressor back to the manufacturer, please include a detailed statement concerning the type of defect or malfunction encountered and describe the ammunition used and type of host weapon the product was used on or attached.

If for any reason your suppressor is not eligible for repair or replacement, you may purchase a replacement suppressor for 50% off the MSRP for a same or similar suppressor. Please contact our Customer Service Department for further details and requirements.

7. LAWFUL USE AND POSSESSION

Your new suppressor is an NFA weapon and is not legal to own or possess in certain jurisdictions. Dead Air Silencers does not offer any express or implied promises or affirmations concerning the use, possession, or ownership of your suppressor. If you have any questions concerning the ownership, possession, or use of your suppressor contact the chief local law enforcement officer in the jurisdiction in which you reside or your local BATF office for further information concerning the ownership, use, and possession of NFA controlled weapons.

HELPFUL OWNERSHIP INFORMATION

ALWAYS MAINTAIN A COPY OF THE APPLICABLE BATF DOCUMENTS TO YOUR SUPPRESSOR WITH THE SUPPRESSOR ITSELF WHENEVER TRANSPORTING OR USING YOUR SUPPRESSOR. FAILURE TO DO SO COULD RESULT IN CONFUSION, PROSECUTION, OR CONFISCATION OF YOUR NFA CONTROLLED WEAPONS. BETTER SAFE THAN SORRY.

8. CONTACT INFORMATION

You can contact us directly by telephone at 801-857-4232, or visit our website at www.deadairsilencers.com.

Thank you once again for supporting our products and feel free to contact us with any inquiries or concerns that you might have.





No Quarter

